

Operating Instructions for the PhosBan Reactor 150™

Technical Data

Capacity	Use with minimum 130 grams (250 ml) up to a maximum of 200 grams (385 ml) of PhosBan.
Aquarium size	One reactor for up to 150 gallons (568 Liters). Multiple reactors may be used for larger aquariums.
Maximum recommended flow rate	ca. 30-50 gal/hr = 115-190 l/hr. Use included ball valve to reduce the flow from any pump.
Connection for hoses	1/2 inch (12.7 mm) i.d. The inlet and outlet flexible 90° fittings rotate to suit your installation.

Important Notes: Do not use a media bag in the PhosBan Reactor 150. Simply place PhosBan inside the assembled reactor according to the instructions. Don't over-pack the column. Use 200 grams (385 ml) maximum of PhosBan per reactor. Do not place ball valve on the exit pipe. Restricting the flow on the exit pipe pressurizes the reactor and can cause leaks. Do not exceed max. flow rate. Too much flow can grind PhosBan.

Description The PhosBan Reactor150™ is designed with the upflow principle to achieve the most efficient use of PhosBan™ or other chemical filter media. By pushing water from the bottom upward through a dispersion plate, it forces an even distribution of water through the media, and prevents channeling.

1. Preparing the Reactor Unpack the reactor. Open reactor lid by turning counter clockwise. Check parts list to confirm that all parts are present. The reactor is supplied with all the parts needed to operate it except for the hose and pump. The pump used can be a powerhead, such as a Maxijet 500, or the supply of water can be tapped off of a circulating pump already in use on the aquarium (see diagrams 1-4 on instructions page two).

If the center tubes are not already glued to the dispersion plates, insert the end of the 9 inch center tube into one dispersion plate until it stops, and slide one of the sponges onto the tube so that it rests on top of the dispersion plate. Insert this assembly into the reactor column. It may be necessary to use tongs or a yardstick to keep the lower sponge resting on top of the dispersion plate when you insert it into the reactor column. Add about 1 cup of water to the reactor. Use a yardstick or tongs to push out the large air bubbles trapped in the lower sponge.

1a. Adding PhosBan media Before adding PhosBan to the reactor, temporarily cover the top of the 9 inch center tube with a piece of tape. This will prevent PhosBan from entering the tube when you add it to the column. To minimize dust evolution, wet the PhosBan first. Use a large spoon or scoop to put the PhosBan into the reactor. After adding PhosBan to the reactor column, remove the tape from the center tube.

1b. Finishing the reactor assembly Attach the remaining dispersion plate onto the top of center tube. Insert the remaining 2 inch length of rigid tube into the top of the dispersion plate (if not glued already). Slide the remaining sponge on top of the center tube above the dispersion plate. Press it down to be sure it is sitting flat all the way around the dispersion plate.

Check to be sure the O-ring is seated properly in the O-ring groove inside the top of the lid. With the reactor sitting upright, attach lid on top of the reactor body by inserting the center collar (located on the underside of the lid) over the top of the center tube. Rotate lid on the threads until it becomes stiff (hand-tight) to seal and close the reactor. Do not overtighten!

2. Locating the reactor The PhosBan reactor can be seated upright in the cabinet, in the filter sump, upright on the floor below the aquarium or hanging on the side or rear of an aquarium. For hanging installations, use threaded bolt provided in the base plate to level it against the aquarium wall. Wherever it is located, the reactor must be upright and level to operate properly. To prevent any risk of back-siphoning, the outlet of the water return hose should not be located below the water line if the reactor is located below the level of the aquarium or below where the return line enters the aquarium or sump. See diagrams 1-4 for suggested installation options.

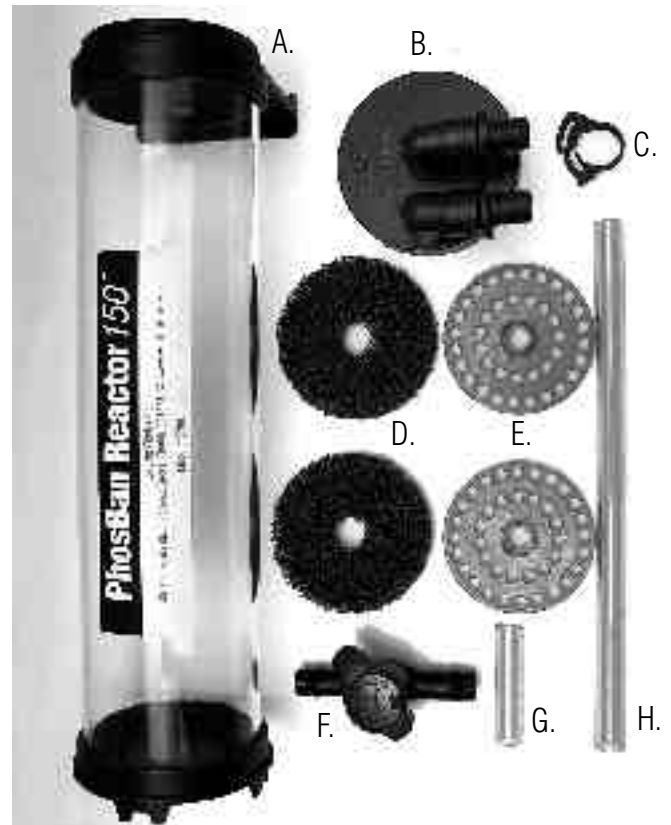

A. Reactor body; B. Lid (Qty: 1); C. Ratchet Clip (Qty: 1); D. Sponges (Qty: 2); E. Dispersion Plate (Qty: 2); F. Ball valve (Qty: 1); G. 2" Tube (Qty: 1); H. 9" Tube (Qty: 1).

3. Connecting to the Pump Using a length of 1/2 inch i.d. hose, attach the ball valve to the water input pipe (center hose barb connector on the lid). Connect another length of hose from the pump output to the ball valve. Connect another length of hose to the reactor water output pipe (outer hose barb connector on the lid) to return water to the aquarium or sump. It is not necessary to use hose clamps to secure the hose connections on the supplied fittings because they are barbed. It may be necessary to use a hose clamp to secure the hose connection to the pump. Check that the lid is securely fastened, the reactor is level, all of the hoses are securely attached, and position the pump in the aquarium or sump.

4. Initial Operation and Adjustment Direct the initial water exiting the reactor into a bucket to catch the PhosBan fines. Open the ball valve, turn on the pump, allowing water to fill the reactor, and then close the ball valve to stop the flow. The PhosBan will settle. Open the valve for 2 to 3 seconds to purge air, then partially close the valve to reduce the flow and allow the initial dusty 1/2 gallon of water to empty into the bucket. When the water runs clear, close the valve and reposition the return hose to feed water back to the aquarium. Adjust the flow rate with the valve so that only the upper 1/2 inch (1.3 cm) of granules tumbles, looking like water beginning to boil.

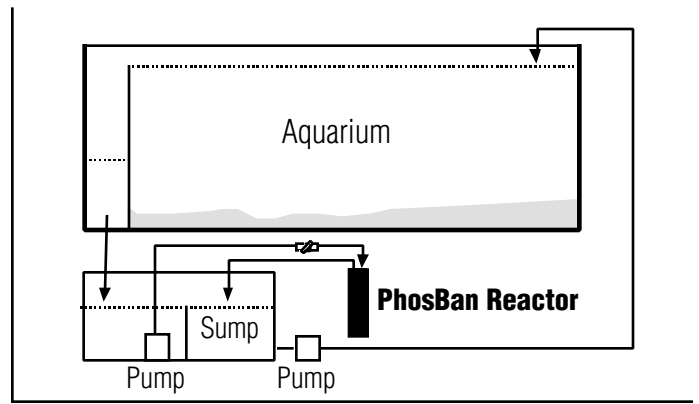

Diagram 1

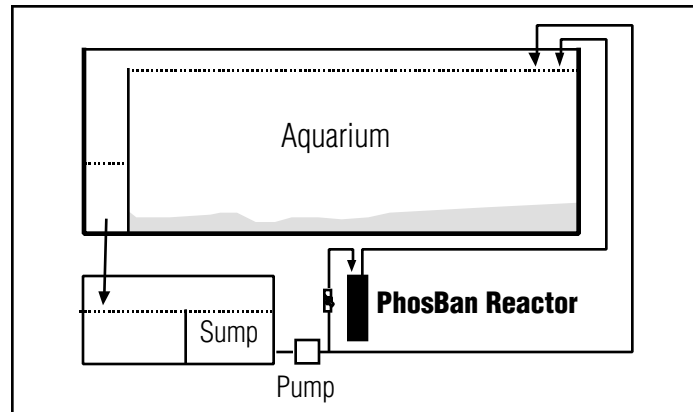

Diagram 2

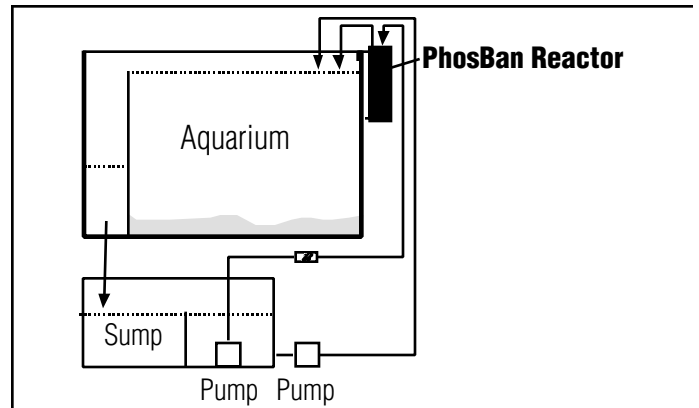

Diagram 3

5. Maintenance When changing the PhosBan, first shut off the pump that sends water to the reactor and close the ball valve. Place reactor inside a bucket to catch any spilled water when you open it. If the return hose is located in the aquarium or a sump above the level where you are servicing the reactor, make sure that the outlet is not located below the water line in the tank. If it is, lift the outlet hose so that it cannot siphon water from the aquarium or sump. Separate the lid from the reactor (the hoses may be left in place). Some water may spill out of the return hose. Pour the water from the reactor into the bucket. Remove the top dispersion plate and sponge. Take the reactor column over a trash bin and spill out the PhosBan media. Rinse the reactor sponges with a strong jet of water. Never use soap or detergents of any kind). Reassemble the reactor per the instructions. Re-start the pump and follow the initial operation and adjustment procedure.

6. Replacement Parts The sponges will periodically need to be replaced. Order them and any other replacement parts through your pet shop, which can order them directly from Two Little Fishies, Inc. or its distributors.

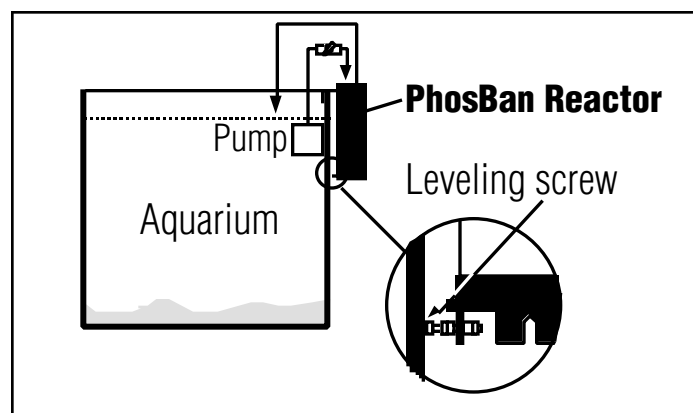

Diagram 4